



PNEUMATIC RIVET NUT SETTER

INSTRUCTION MANUAL

N 1 A 2

CONTENTS



INTRODUCTION.....	1
IMPORTANT SAFETY INSTRUCTIONS	2
NOMENCLATURE.....	5
TECHNICAL DATA.....	6
PREPARATION BEFORE USE...7	
OPERATING THE PNEUMATIC RIVET NUT SETTER	13
MAINTENANCE	14
PARTS TABLE	17
STORAGE	21
ORDERING PARTS.....	21
TROUBLESHOOTING.....	22

英語 / ENGLISH

Professional model of pneumatic rivet nut setter to install blind rivet nuts.

Thank you very much for purchasing "LOBSTER" pneumatic rivet nut setter. To ensure correct operation, please read this instruction manual carefully, and keep it in a safe place for later reference.

This is Original instructions. (Original Instruction Manual is written in English language.)

MANUFACTURER
LOBTEX CO., LTD.
 International Marketing & Sales Division
 12-8 Shijo-cho, Higashi-Osaka City
 Osaka 579-8053, Japan

Telephone: +81(72)981-7466 Telefac: +81(72)981-9420
 URL <http://www.lobtex.co.jp/>

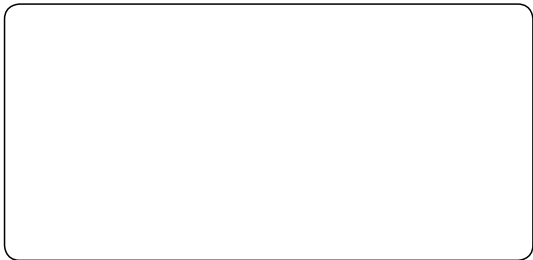

PRINTED IN JAPAN

● INTRODUCTION

- This is exclusive tool to install blind rivet nuts.
- This instruction manual shows how to operate and to do maintenance and inspection in order to use with safety and efficiency.
- Use appropriate blind rivet nuts which are fully designed and examined to there specification and strength.

1 IMPORTANT NOTICES

- Read this manual carefully before using this tool. Follow instructions in this manual for handling this tool, replacing accessories or replacing parts as needed.
- If you have any questions about this manual, check the model (type) and contact the “LOBSTER” dealer where you purchased the tool.
- It is impossible to foresee all potential dangers and describe them in this manual. You must use this tool paying attention to safety as well as observing the instructions in this manual.
- It is user's responsibility to understand the contents of this manual thoroughly.
- Lobtex Co., Ltd. has the copyright of this manual. It is prohibited to publish, copy or translate to other language without prior consent.

2 INDEMNIFICATION

- Our warranty does not apply to direct and indirect damages and lost income caused by the misuse, abuse, and unauthorized modification of the tool. We do not guarantee the strength or quality of blind rivet nuts.
- We do not guarantee any damages and failures caused by any modifications without our written approval.
- We do not guarantee any damages and failures caused by use of parts other than our recommendation.

● IMPORTANT SAFETY INSTRUCTIONS



◆ Be sure to read the following Important Safety Instructions carefully and make sure that you understand them thoroughly before using this tool.



◆ Always wear protective goggles while you use the tool. Otherwise, you may incur accidents or injuries (blindness) caused by thrown parts or splashing oil.



◆ This is the safety alert symbol. It is used to alert you to potential personal injury hazards. Obey all safety messages that follow this symbol to avoid possible injury or death.

◆ The Important Safety Instructions are divided into **⚠ WARNING** and **⚠ CAUTION**.

The differences between these two levels are described below.

⚠ WARNING : Indicates a potentially hazardous situation which, if ignored, could result in death or serious injury to the operator.

⚠ CAUTION : Indicates a potentially hazardous situation which, if ignored, may result in moderate injury to the operator or physical damage.

Moreover, failure to follow the instructions marked with the **⚠ CAUTION** symbol or cautions without a **⚠ CAUTION** symbol which appear in the text of this manual may also have serious results in some cases. Always be sure to observe the instructions given in the Important Safety Instructions.

◆ After reading this manual, keep it in a safe place where it is easily accessible to tool users.

⚠ WARNING

1. The air pressure should be kept within the range of 0.5 to 0.6 MPa .

• If an air pressure which is greater than this is used, the tool may become damaged, and injury or damage to property may result.

2. When adding hydraulic oil through the air cylinder, be sure to loosen the bleed plug afterwards to allow any excess hydraulic oil to drain away.

• If excess oil is allowed to remain inside the tool, damage to the tool or personal injury may result.

3. Always wear protective goggles while you use the tool.

• You may incur accidents or injuries (blindness) caused by thrown parts or splashing oil.

4. Make sure that the tool and the air source are connected securely.

• If the threads of the joints do not match or if the screws are not inserted far enough, the air hose may become disconnected during use and injury may result.

• Use hose bands to securely connect the air hose joint and air hose. If they are not securely connected, the air hose may become disconnected during use and injury may result.

5. Turn off the air supply before disconnecting the tool from the air source.

• Compressed air may cause the air hose to whip around, and injury may result.

6. Check that all screws are securely fastened before using the tool.

• If any of the screws are not sufficiently tightened, they may fall out during use and accidents or injury may result.

7. Check that all the tool parts are free from damage before use. Any damaged parts should be repaired before the tool is used.

• If the tool is used while any parts are damaged, injury may result.

• If the tool is damaged by objects being dropped onto it, the damaged part may break and accident or injury may result.

• Don't pull and drag the tool by the air hose. It may trigger some damages on the tool body, breakage of Rotary Joint or some other defects and lead serious troubles with injuries.

8. If using in elevated locations, use a safety harness, and take care to avoid dropping rivets or the tool itself.

• Accident or injury may result if this practice is not followed.

9. Do not touch switches except to install blind rivet nuts.

• The tool may operate unexpectedly, causing accidents or injuries.

10. Ensure that the nosepiece is securely attached.

• Accidents or injuries may otherwise result if the tool operates unexpectedly.

CAUTION

- 1. Before starting maintenance or disassembling the unit to replace parts, be sure to stop air supply.**
 - Performing maintenance or disassembly with air supplied may cause a part to jump out, oil to squirt out, or the unit to perform unexpectedly, and may result in an accident or personal injury.
- 2. Adjust the pulling stroke correctly.**
 - If the stroke is too short, the rivet nut may not be pulled up sufficiently, effecting its clamping ability.
 - If the stroke is too long, the threads of the rivet nut may strip effecting the strength of the fastener.
 - Each blind rivet nuts may have different pull up stroke requirements according to its manufacturer, materials, and size. Check the pull up stroke requirements for used blind rivet nuts.
- 3. Do not operate the tool without equipped the frame head.**
- 4. Do not bring your face close to the air outlet holes.**
 - Pressurized air containing fine particles is discharged from the air outlet holes during use. Keep eyes away from this area.
 - Oil spouted from the air outlet holes may splash onto and dirty clothes or property.
- 5. Avoid skin contact with substances such as hydraulic oil, lubricating oil and grease.**
 - Such substances may cause inflammation of the skin. If they come into contact with your skin, wash the affected area thoroughly.
- 6. The parts to be used must be those supplied from Lobtex or recommended by Lobtex. Select and attach parts applicable to your nut.**
 - Otherwise the unit may not produce maximum performance and may malfunction resulting in an accident or personal injury.
- 7. Make sure that the workplace is safe, clean and organized.**
 - Accidents can easily occur in untidy workplaces.
- 8. Ensure sound footing and do not work in an unnatural posture.**
 - You may fall and injure yourself.
- 9. Keep people who are not involved in work away from the workplace.**
 - Accidents or injury may result.
- 10. Maintain the tool with care.**
 - Refer to the Instruction Manual for details on replacing parts and attachments, otherwise injury may occur.
- 11. Keep the hand grip dry and clean, and avoid adhesion of oil and grease.**
 - Otherwise the grip may slip from your hand resulting in falling of the unit.
- 12. Use the tool carefully and concentrate on correct operation at all times.**
 - Use the tool with proper care, paying full attention to methods of handing and operation and surrounding conditions. Accidents and injury may result if this practice is not followed.
 - Use common sense at all times, otherwise accidents or injury may result.
 - When you are tired, do not use the tool, otherwise accidents or injury may result.
- 13. Ask Lobtex to carry out any repair work required.**
 - Repair work should only be carried out by a qualified technician. Please contact your nearest "LOBSTER" distributor, representative, or direct to Lobtex Co.,Ltd.,Osaka. If the tool is repaired by someone without the necessary qualifications and experience, the tool may not perform to optimum standards, and accidents or injury may result.
- 14. Do not attempt to modify the tool.**
 - Unauthorized modifications may cause malfunctions which can lead to accidents or injury.

CAUTION

15. The year and month of production of the tool are indicated by a code and four-digit number on the cylinder cap (see page 6).
16. Warning labels include important information and tips on using the tool. If the labels become so dirty or damaged that they cannot be read, order and replace them with new labels.
You can order new labels from Lobtex Co., Ltd. through our dealers.
17. When disposing of the tool or packing materials, observe local laws and codes on waste disposal.
18. This product is a tool for exclusive use of the professional business. When you are the one who uses this tool for the first time, please receive an instruction from the one who has already used this tool before, also please read the Instruction Manual carefully and understand the content.
19. Comply with the following tool maintenance guidelines: Clean the tool on the inside (such as the cylinder cup and screw mandrel) and change the hydraulic oil with fresh oil every year or every 30,000 pcs of work.
20. Only persons who are well trained and qualified should use, adjust, and maintain this product.
 - Only persons who can physically handle the capacity, weight, and performance of the tool should use it.
21. Slips, trips and falls are major causes of workplace injury. Be aware of slippery surfaces caused by use of the tool and also of trip hazards caused by the air hose.
22. Proceed with care in unfamiliar surroundings. There can be hidden hazards, such as electrical or other utility cables.
23. This tool is not intended for use in potentially explosive atmospheres and is not insulated against contact with electric power.
24. Ensure that there are no electrical cables, gas pipes, etc., which can cause a hazard if damaged by use of the tool.
25. Using the tool repeatedly may cause pains in your hands, shoulders, neck, and other locations.
 - To avoid pain and fatigue, assume an appropriate and natural posture, and change your posture as necessary.
 - If you suffer from continuous discomfort, pain, numbness, palpitations, stiffness, or hot flashes, do not ignore it. Consult with your employer and health manager.
26. Compressed air can cause severe injury:
 - Never direct air at yourself or anyone else.
27. Whipping hoses can cause severe injury.
 - Always make sure there are no damages on hoses and no loose fittings.
28. Do not drag or carry this tool by pulling the hose.
29. Preventative maintenance should be carried out, after a specified time of operation, a specified number of cycles/operations or a stated number of times per year.
30. When you handle oil or grease, obtain the material safety data sheet (SDS) from the supplier, and follow the described instructions.
31. Failure to secure the nosepiece runs the risk of crushing and pinching.
 - It may cause accidents and injuries.
32. Hold and use the product appropriately in order to cope with sudden motions.

● NOMENCLATURE

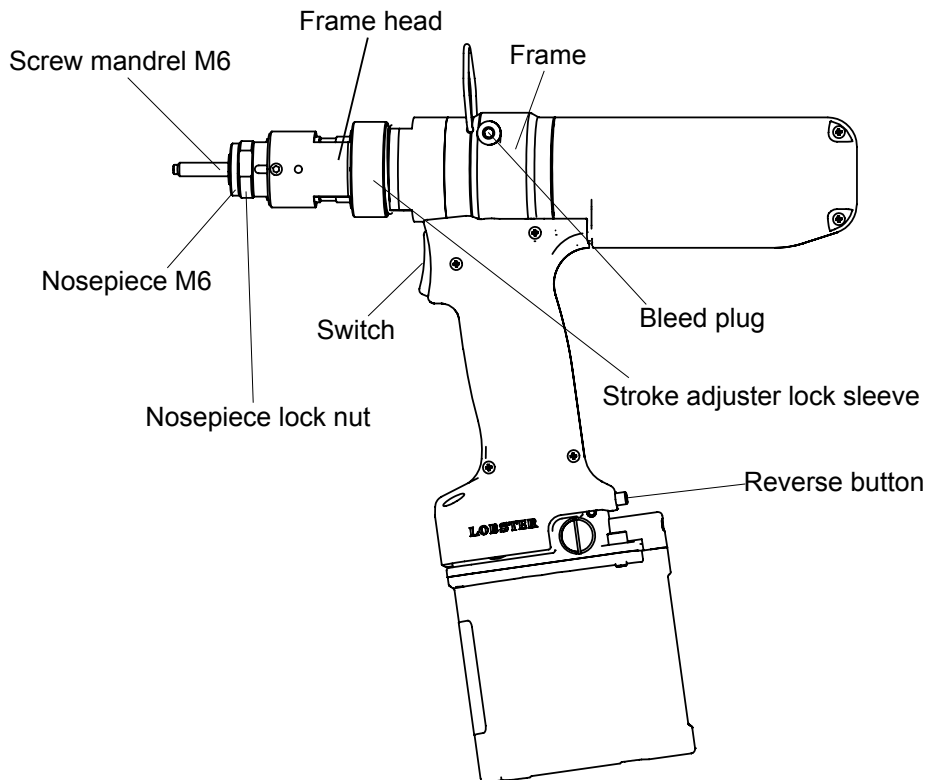

■ ACCESSORIES ■ Check at the time of purchase.

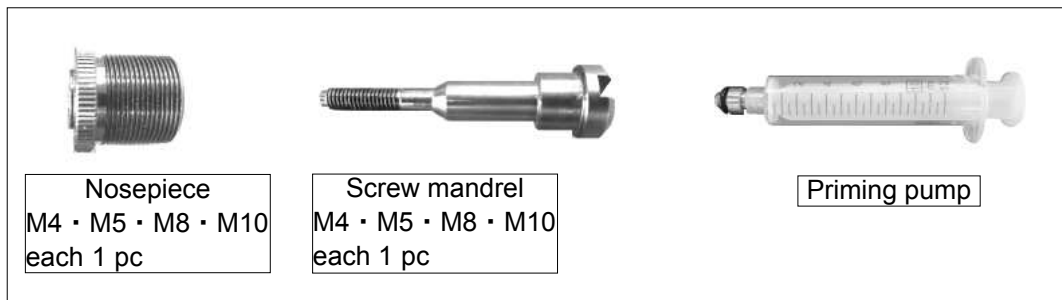

※ Optional M3 and M12 nosepieces and screw mandrels are necessary to install M3 and M12 rivets.

● TECHNICAL DATA

Model No.		N1A2
Weight	kg	2.1
Operating air pressure	MPa	0.5 ~ 0.6
Dimensions (Length×Height×Width)	mm	305×298×114
Air consumption per rivet nut at 0.6MPa	ℓ	3
Tool stroke	mm	7
Traction power at 0.6MPa	kN	25
Applicable nuts		M3 · M4 · M5 · M6 · M8 · M10 · M12 ※①
Operating environment	Temperature	5°C to 35°C
	Relative humidity	80% RH max (no condensation)
Sound	Pressure level(Lpa)	80dB
Vibration at 0.6MPa	m/sec ²	1.1
Air intake (Rotary joint)		G1/4 (PF1/4)

- ※ Product specifications and design are subject to change for improvement without notice.
- ※ Weight and dimensions given are standard values. Actual products may differ slightly from the values given.
- ※ The rating plate (note: warning plate attaching location) is on the side of the cylinder cup.
- ※ The year and month of production of the tool are indicated by a code and four-digit number on the cylinder cap.
- ※① Only for blind rivet nuts that can be pulled up at 25 kN.

■ Air consumption calculation method ■

Use the following calculation method to obtain the required air consumption, and select the compressor accordingly.

Required air consumption = Air consumption per nut × Numbers of nuts to be worked per minute

Make sure that this corresponds to the compressor discharge capacity(per minute.)

How to read the year and month of production

A year/month of manufacture	1	2	3	4	5	6	7	8	9	10	11	12
An English character	A	B	M	N	K	W	T	Y	U	O	L	Z

Example

year: 2 0 1 ④ month: ⑧ → N Y ○ ○ ○ ○
 ↓ ↓ ↓
 N Y (Serial No.)

Revision history of instruction manual
Item : Pneumatic rivet nut setter
Model : N1A2
Date of first edition: August , 2015
Date of second edition: November , 2015
Date of third edition: February , 2016

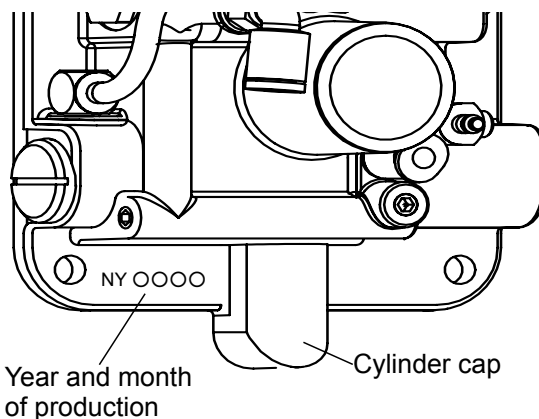

● PREPARATION BEFORE USE

- 1 Set up the compressor, and be sure to install an air filter, air regulator and air lubricator (3-device set) between the compressor and the tool.

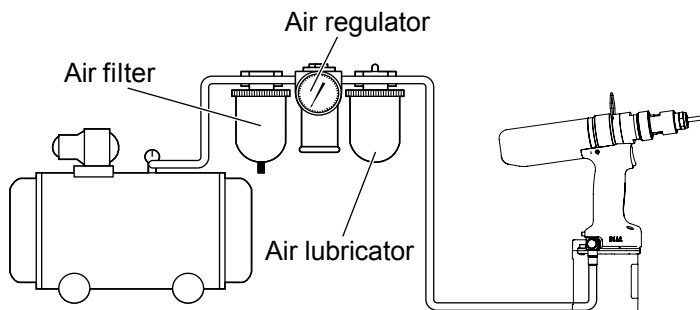

ATTENTION:

If moisture enters inside of the unit, it may freeze in cold temperature or accelerate degradation of O-rings and packings, resulting in malfunction of the unit. To avoid that, use an air dryer as necessary in addition to an air filter, regulator and an air lubricator (3-device set)

- 2 Use the air regulator to adjust the operating air pressure to 0.5 ~ 0.6MPa.

⚠ WARNING 1 (P.2)

ATTENTION:

- Excessively high air pressure may damage parts, while excessively low air pressure may cause incomplete riveting of rivet nuts.

- 3 Replace the screw mandrel and nosepiece with those appropriate for the rivet nuts to be used.

- ◎ The tool can be used with nuts of each sizes by simply replacing with the screw mandrel and nosepiece with the appropriate parts.
- ◎ An M6 screw mandrel and nosepiece are set to the tool at time of purchase.

- 4 Replacement of screw mandrel and nosepiece

■ How to replace ■

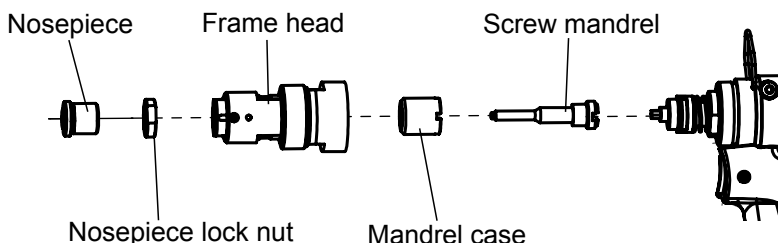

How to replace the screw mandrel and nosepiece

1 Remove the nosepiece.

※ Always turn off the air supply
before replacing parts. **CAUTION 1 (P.3)**

Turn the nosepiece lock nut (width across flats: 22) counterclockwise, and remove the nosepiece and nosepiece lock nut from the frame head.

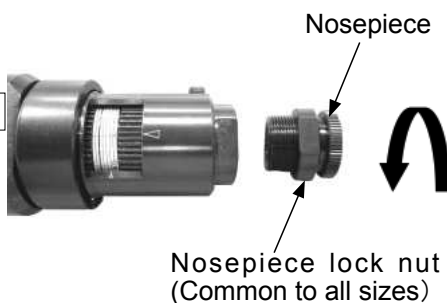

2 Remove the frame head.

Turn the frame head with an adjustable spanner (width across flats: 36) counterclockwise to remove it. (Turn it clockwise to fasten it.)

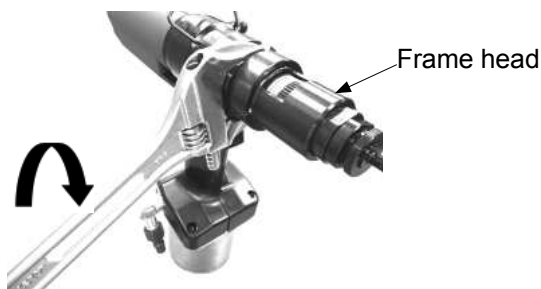

3 Remove the mandrel case.

The projecting part of the stop ring catches the recess part of the mandrel case to lock in place.

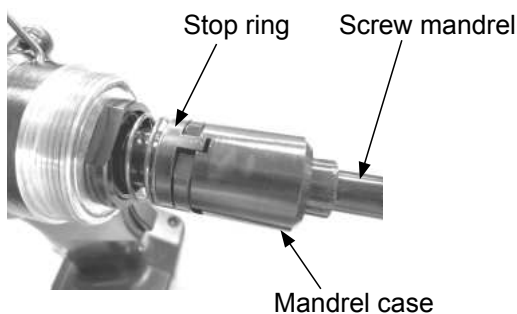

Shift the stop ring, turn the mandrel case counterclockwise, and remove the mandrel case and screw mandrel.

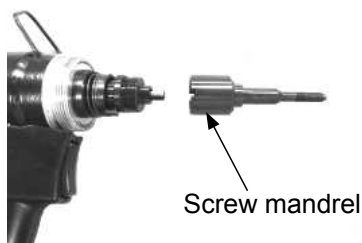
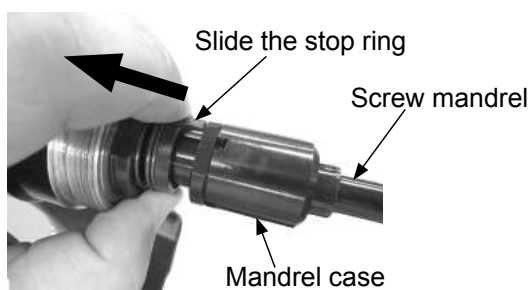

4 Replace the screw mandrel and nosepiece with those appropriate for the rivet nuts to be used.

Always apply grease to the collar of the screw mandrel and lubricant to the threaded section of the same.

※ When replacing the screw mandrel only, follow steps **2** to **4**.

5 Adjust Nosepiece lock nut to change active length of Nosepiece.

When the rivet nut is set to the mandrel, make sure that thread part will be showed about 1 pitch from rivet nut.

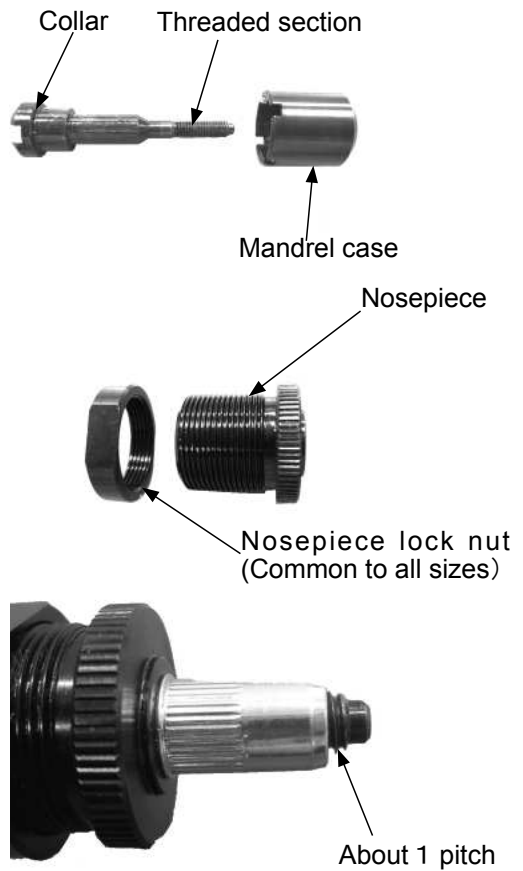

5 Be sure to adjust the stroke to set the rivet nuts correctly.

NOTE Required stroke will change depending on the material and size of each rivet nut and the thickness of workpiece. If any of the above will be changed, adjust the stroke appropriately again.

■ STROKE ADJUSTMENT ■

1. Measure the material thickness.
2. Check the required stroke from the graph.

■ For example

● Supposing the nuts are installed in 1.0mm(t) material thickness, the appropriate stroke is 3.5mm (ℓ) .

ATTENTION

Each blind rivet nuts have an appropriate stroke. Make sure the appropriate stroke referring to the instruction manual and setting stroke list attached to the nuts which is used.

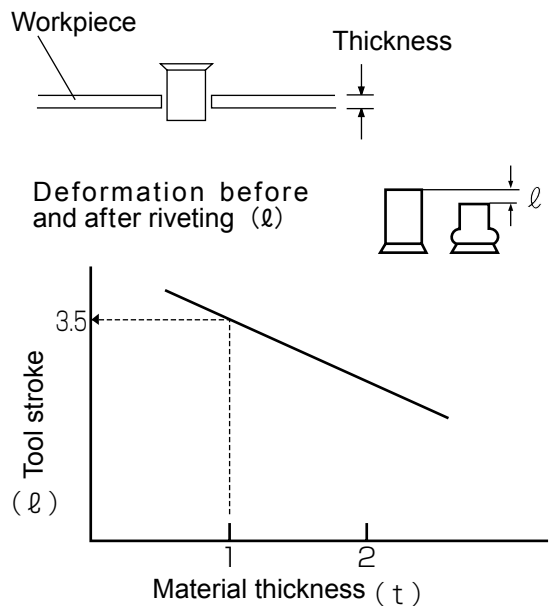

How to adjust stroke

- 1** Measure the overall length of the rivet nut before riveting (to adjust the stroke later).



- 2** Loading a rivet nut

Push a rivet nut into the screw mandrel to automatically load it.

Without pulling the switch, the screw mandrel automatically rotates in the clockwise direction and loads the rivet nut as it is pushed inward.

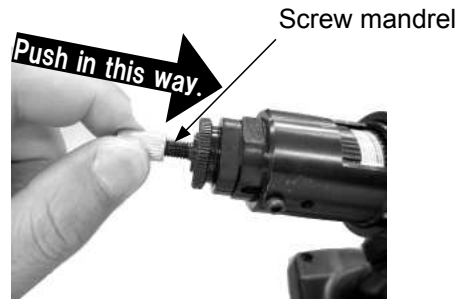

- 3** Completion of rivet nut loading

When the rivet nut comes in contact with the nosepiece after it has been loaded, the clutch operates and a continuous clicking sound is emitted. Release the rivet nut.

Be sure to load the rivet nut until the clutch operates. Failure to contact the nosepiece causes incomplete riveting.

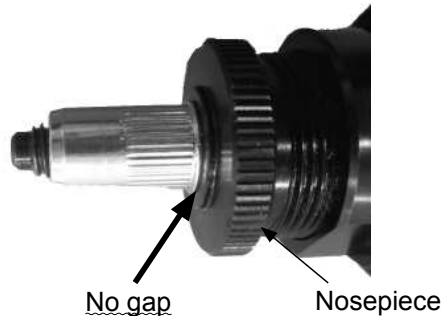

- 4** Riveting >> Rotation in reverse direction

Keep pulling the switch until the rivet is set and the screw mandrel rotates in reverse.

By pulling the switch the screw mandrel goes backward and the rivet nut is set. Maintaining the switch in the pulled position automatically rotates the screw mandrel in reverse, which allows the rivet nut to be removed. Releasing the switch stops the screw mandrel from rotating in reverse.



5 Measurement of the rivet nut
Measure the rivet nut after riveting.

Subtracting the overall length of the rivet nut after riveting measured in this step **5** from that measured in the step **2** obtains the actual stroke.



6 Adjustment of stroke

Adjust the stroke to each rivet nut setting capacity.

Turn the stroke adjusting dial and slide the stroke adjusting dial lock sleeve in the direction of the arrow to adjust the stroke.

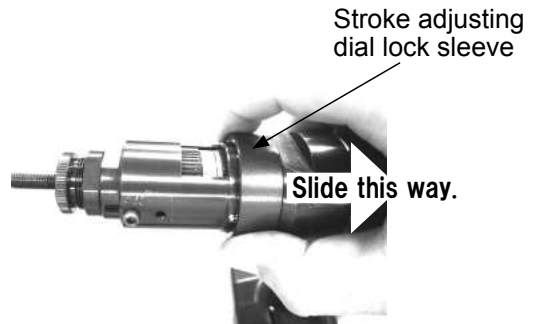

Repeat steps **2** to **6** until the stroke is appropriate.

Turning the stroke adjusting dial in the "+" direction shown in the photo on the right increases the stroke. Turning it in the "-" direction shown in the photo on the right decreases the stroke.

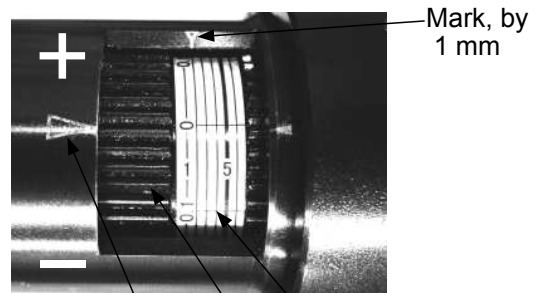

※ To operate the air motor smoothly, lubricate with 3 - 5 drops of LOBSTER hydraulic oil "B10012" (optional) from the air coupler before starting work.



Mark, by 0.1 mm

6

Precautions when using the Pneumatic rivet nut setter

Worn or damaged threads in the screw mandrel (mandrel) prevents proper use.
Pay close attention to M3 to M5 mandrels, since they are thin and vulnerable to damage.
Observe the following.

- ① **Stroke greatly in excess of the appropriate level leads to an excessive stroke.**
⇒ Blind rivet nuts (hereafter called “nuts”) have each an appropriate stroke, depending on the manufacturer, material, and size. Refer to the instruction manual and setting stroke list attached to the purchased nuts. If you cannot find the appropriate stroke, contact the nut manufacturer to find the appropriate stroke.
- ② **Use the nosepiece appropriate for the mandrel size.**
⇒ Use of an excessively large mandrel prevents appropriate riveting.
- ③ **Lubricate the mandrel after every 20–30 pcs. nuts have been set.**
- ④ **When riveting, prevent the mandrel from interfering with the workpiece.**
- ⑤ **Pay attention not to damage the mandrel threads when storing the tool.**
⇒ Thinning, deformation, and burrs on the threads may prevent proper riveting.
- ⑥ **Load the nut until it touches the nosepiece.**
⇒ Gapping between the nut and nosepiece may prevent appropriate riveting, leading to degraded setting torque and deformation of the workpiece, as well as damage to the mandrel threads.
- ⑦ **Do not set the nut again which has already been used.**
⇒ Setting the nut again which has already been used applies a heavy burden on the nut and mandrel. In a worst case scenario, it may be impossible to remove the nut from the mandrel.
- ⑧ **Never pull the switch again once you release it while working.**
⇒ Push the reverse button. The mandrel rotates in reverse and releases the workpiece.
- ⑨ **Check for flaws in the nuts and surroundings such as prepared holes and plate thickness.**
⇒ Some nuts with thread flaws may not be set normally.
- ⑩ **You cannot operate the tool continuously by keeping the switch pulled. Release the switch before starting the next operation.**
- ⑪ **Keep the pneumatic rivet nut setter in a vertical posture while using it.**
⇒ Other postures may cause slanted nuts or damage to the mandrel.

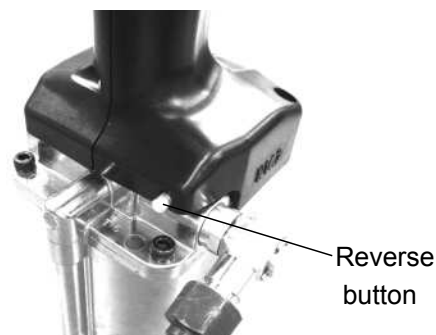

● OPERATING THE PNEUMATIC RIVET NUT SETTER

1 Drill a hole of the appropriate size into the workpiece.

2 Push a rivet nut into the screw mandrel to load it. Without pulling the switch, the screw mandrel automatically rotates in the clockwise direction and loads the rivet nut as the screw mandrel is pushed inward.



3 When the loaded rivet nut comes in contact with the nosepiece, the clutch operates and emits a clicking sound. At that point, release the rivet nut.



4 In the state of the step **3** above, insert the rivet nut into the prepared hole in the workpiece.

5 When you pull the switch, the screw mandrel reverses and the rivet nut will be fixed to the workpiece. Keeping the switch pulled automatically reverses the screw mandrel and releases the rivet nut. Releasing the switch stops the reverse rotation of the screw mandrel.



If the screw mandrel cannot release the rivet nut

※ Be sure to turn off the air supply. **⚠ CAUTION 1 (P.3)**

Screw a hex socket bolt of M4×10 or longer into the M4 hole of the frame head.

Then, the screw mandrel locks.

Turn the pneumatic rivet nut setter counterclockwise to remove the screw mandrel from the workpiece.



Hex socket bolt
(M4×10 or longer)

Important

Be sure to remove the hex socket bolt (M4×10 or larger) before riveting again. Re-riveting with the hex socket bolt attached may damage the screw mandrel.

● MAINTENANCE

1 Cleaning and oil supply of air cylinder section

- ◎ Accumulated dusts in the air cylinder section will adversely affect smoothness and durability.
- ◎ If the tool runs low on hydraulic oil and does not produce an adequate stroke, lubricate the tool with LOBSTER hydraulic oil "B10012" (optional) by following the procedure below. If stroke is again inadequate soon after hydraulic oil has been refilled, the seal section may be worn or damaged.

DISASSEMBLY

1 Turn off air supply.  CAUTION 1 (P.3)

2 Using a hex key wrench (AF4mm) remove the 4 hex socket bolts on the top surface of cylinder cap.

※ Tilting the main body may cause the hydraulic oil to spill out. Keep it standing up during work.

3 Turn the unit and keep it straight up as the cylinder cap comes to the top, and pull out the cylinder cap upward.

4 Pull out the air piston unit upward.

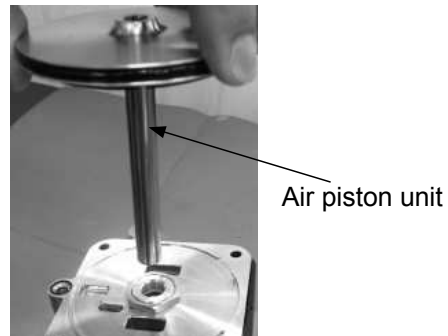
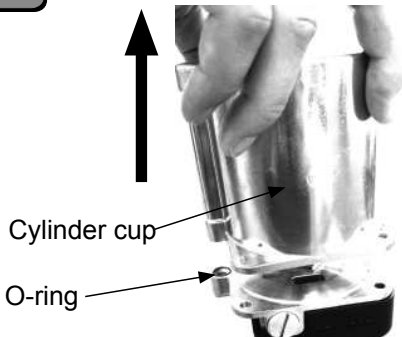
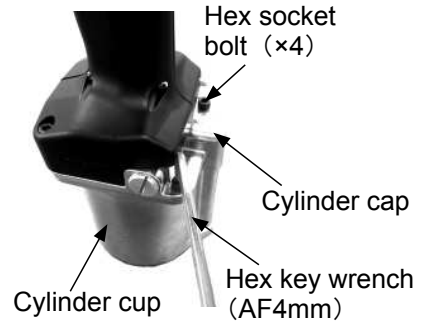

CLEANING

5 Clean each part using a waste cloth and brush.

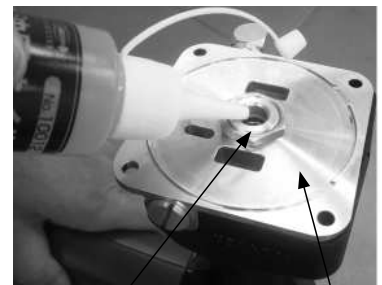

FILLING OIL

6 Supply LOBSTER hydraulic oil (B10012) (separately sold) to the oil supply port of cylinder cap until the oil almost overflows.

※ Hydraulic oil used (viscosity)...ISO VG46

英語/ENGLISH

7 Apply grease to the O-ring and rod of air piston unit and to the inside of cylinder cup using brush.



Apply grease

Air piston unit

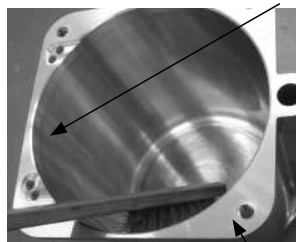

Apply grease

Cylinder cup

8 Push the air piston unit into the oil supply port, and manually move the piston up and down 2 - 3 times. Then, wipe away the hydraulic oil that spills from the oil supply port.

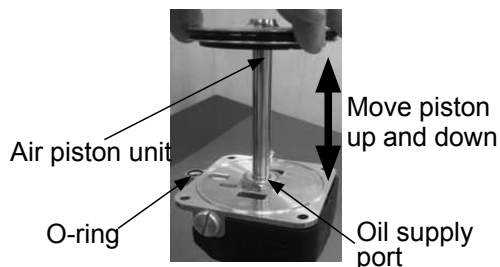

Air piston unit

O-ring

Move piston up and down

Oil supply port

9 Attach the cylinder cup on the air piston unit, and keeping pressing it down tighten the 4 hex socket bolts.

- ※ Assemble in reverse order of disassembly.
- ※ Make sure the O-ring SS10 is surely set in the counterbore.

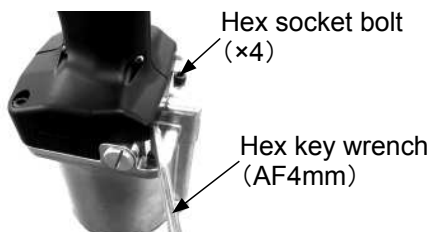

Hex socket bolt (x4)

Hex key wrench (AF4mm)

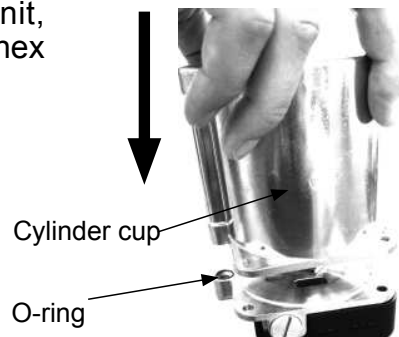

Cylinder cup

O-ring

10 Supply air.

11 Turn the unit as the bleed plug (hex socket bolt) comes to the upper side, and loosen it by using a hex key wrench (AF4mm) in order to let excessive hydraulic oil and air (bubble) out. After making sure that hydraulic oil does no longer comes out, tighten the bleed plug again.

- ※ Hydraulic oil may squirt out when you loosen the Bleed plug.
- ※ This procedure should be done after adding hydraulic oil. Otherwise, it may prevent the tool from loading rivet nuts or damage the frame.

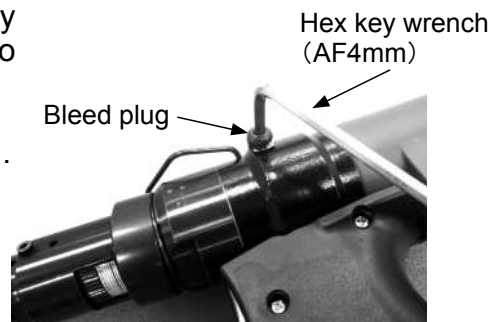

Hex key wrench (AF4mm)

Bleed plug

12 Wipe off hydraulic oil adhering to the main body or spilling out before use.

⚠ CAUTION 5 (P.3)

⚠ CAUTION 11 (P.3)

NOTE: ● During disassembly/assembly, be careful to prevent cutting dusts of metal and other objects from getting inside the hydraulic oil and air cylinder.

2 How to add oil with a priming pump (syringe unit)

© Oil should always be added by following the simple procedure given below.

DISASSEMBLY

1 Turn off the air supply.

 CAUTION 1 (P.3)

2 Remove the bleed plug (hex socket bolt) using a hex key wrench (AF4mm), and attach the priming pump (syringe unit) in the place of the bleed plug.

- ❑ Make sure that the priming pump contains the necessary amount of oil beforehand.
- ❑ If you hold the main body of the priming pump while tightening, the pump may be damaged. Grip the nozzle of the priming pump with pliers while tightening.



FILLING OIL

3 Gently depress the piston of the priming pump.

- ❑ Add about 3 mL of hydraulic oil (15 mm on the priming pump scale).



RE-ASSEMBLY

4 Install the bleed plug.

5 Supply air.

Caution Do not press the switch. It may affect the stroke of the tool.

6 Loosen the bleed plug. Excess oil comes out.

Caution ① Do not press the switch. Oil will spew.
② Loosening the bleed plug all at once may cause oil to spew.

7 Fully wipe away discharged excess oil with a waste cloth.

8 Tighten the bleed plug.

PARTS TABLE

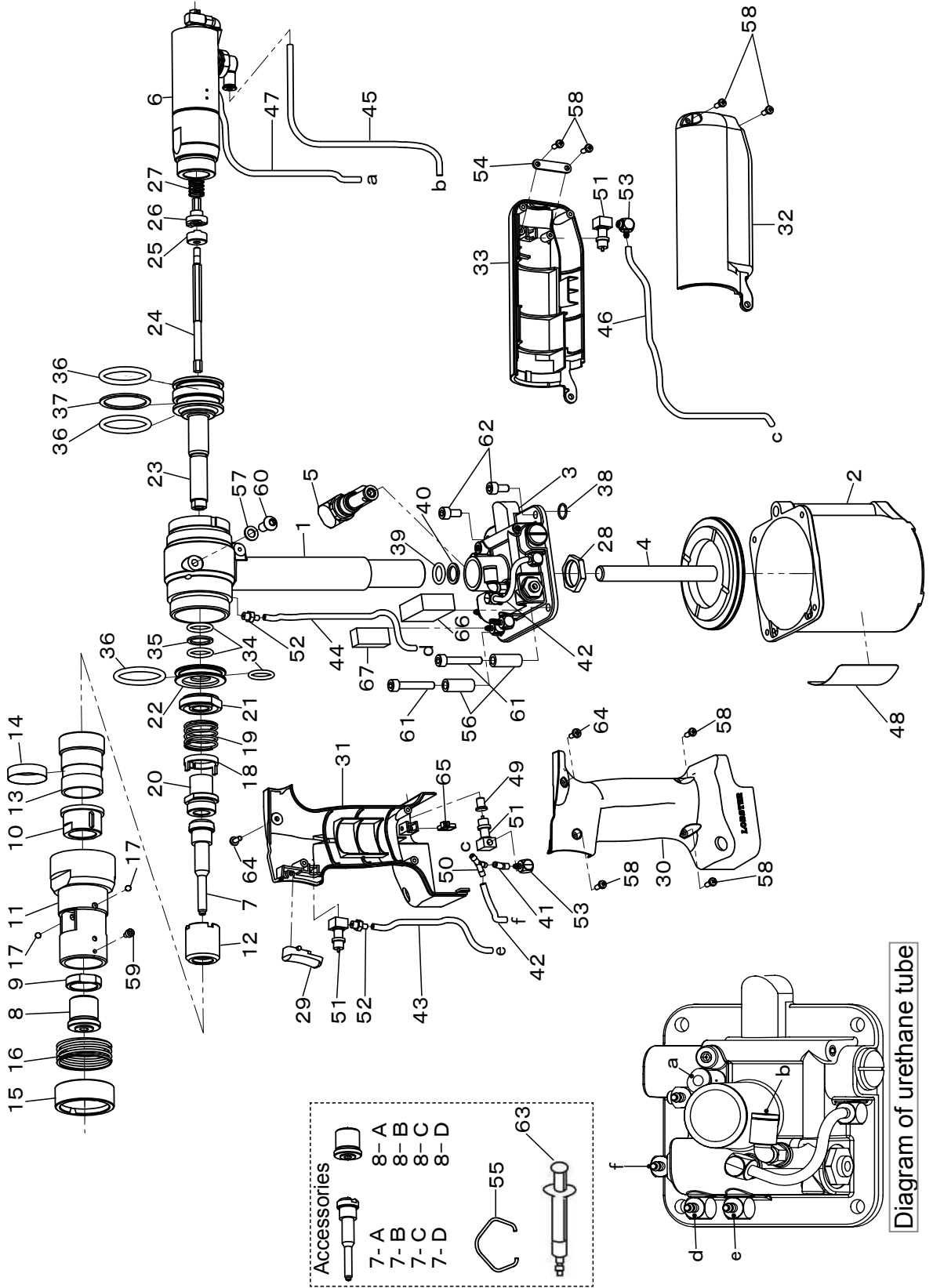

Index No.	Part name	Code No.	Material	Index No.	Part name	Code No.	Material
1	Frame	64892	Aluminum	32	Air motor cover LH	64931	Plastic
2	Cylinder cup	64921	Aluminum	33	Air motor cover RH	64916	Plastic
3	Cylinder cap unit	64882	①	34	O-ring P-14	10434	Rubber
4	Air piston unit	64883	②	35	B-ring P-14	10435	Plastic
5	Spool connector unit	64887	②	36	O-ring P-30	14445	Rubber
6	Air motor unit	64886	③	37	B-ring P-30	64963	Plastic
⑦	M6 Screw mandrel	64936	Steel	38	O-ring SS-10	63179	Rubber
⑦-A	M4 Screw mandrel	64934	Steel	39	O-ring P-11	23663	Rubber
⑦-B	M5 Screw mandrel	64935	Steel	40	B-ring P-11	40109	Plastic
⑦-C	M8 Screw mandrel	64937	Steel	41	Urethane tube 25	64951	Plastic
⑦-D	M10 Screw mandrel	64938	Steel	42	Urethane tube 50	64952	Plastic
8	M6 Nosepiece	64943	Steel	43	Urethane tube 110	64953	Plastic
8-A	M4 Nosepiece	64941	Steel	44	Urethane tube 145	64954	Plastic
8-B	M5 Nosepiece	64942	Steel	45	Urethane tube 200	64955	Plastic
8-C	M8 Nosepiece	64944	Steel	46	Urethane tube 215	64956	Plastic
8-D	M10 Nosepiece	64945	Steel	47	Urethane tube 245	64909	Plastic
9	Nosepiece lock nut	64947	Steel	48	Warning label	64910	④
10	Nosepiece base	64904	Steel	49	Reverse button	64975	Aluminum
11	Frame head	64901	Steel	50	Mini fitting coupling (VGY-208)	64920	Plastic
⑫	Mandrel case	64923	Steel	51	Valve unit	29350	Brass
13	Stroke adjusting dial	64902	Steel	52	Barb coupling for soft tube	43732	Brass
14	Adjusting dial seal	64903	④	53	Barb elbow for soft tube	63226	Brass
15	Stroke adjusting lock sleeve	64977	Steel	54	Valve unit anchor plate	64917	Steel
16	Stroke adjusting lock spring	64978	Steel	55	Hanger	15468	Steel
17	Steel ball φ 4	12917	Steel	56	Grip collar	64932	Aluminum
18	Stop ring	64925	Steel	57	Sealing washer	63209	Rubber
19	Stop spring	64928	Steel	58	Tapping screw for synthetic resin M3X8	64969	Steel
20	Lock sleeve	64924	Steel	59	Hex socket bolt M3X5	43736	Steel
21	Lock nut	64927	Steel	60	Bleed plug	63213	Steel
22	Return piston	64922	Aluminum	61	Hex socket bolt M5X30	64971	Steel
23	Oil piston	64900	Steel	62	Hex socket bolt M5X10	64409	Steel
24	Conveyor rod	64926	Steel	63	Priming pump	29624	Plastic
25	Clutch A	64948	Steel	64	Cross recessed pan head screw M3X8	20860	Steel
26	Clutch B	64949	Steel	65	Cable tie KB100	64919	Plastic
27	Clutch spring	64950	Steel	66	Sponge A	66080	Plastic
28	Frame mounting nut	63228	Steel	67	Sponge B	66081	Plastic
29	Switch	29348	Plastic	—	—	—	—
30	Grip cover LH	64929	Plastic	—	—	—	—
31	Grip cover RH	64930	Plastic	—	—	—	—

Parts with circled Index No. are consumable parts. They should be replaced periodically.

Sold separately

Part name	Code No.
M3 Screw mandrel	64933
M12 Screw mandrel	64939
M3 Nosepiece	64940
M12 Nosepiece	64946
Hydraulic oil in a bottle	10012
Lubricant oil JO-50	889

Unit parts materials

- ① Aluminum, Rubber
- ② Aluminum, Rubber, Steel
- ③ Aluminum, Rubber, Steel, Plastic
- ④ Paper, Plastic

Cylinder cap unit (64882)

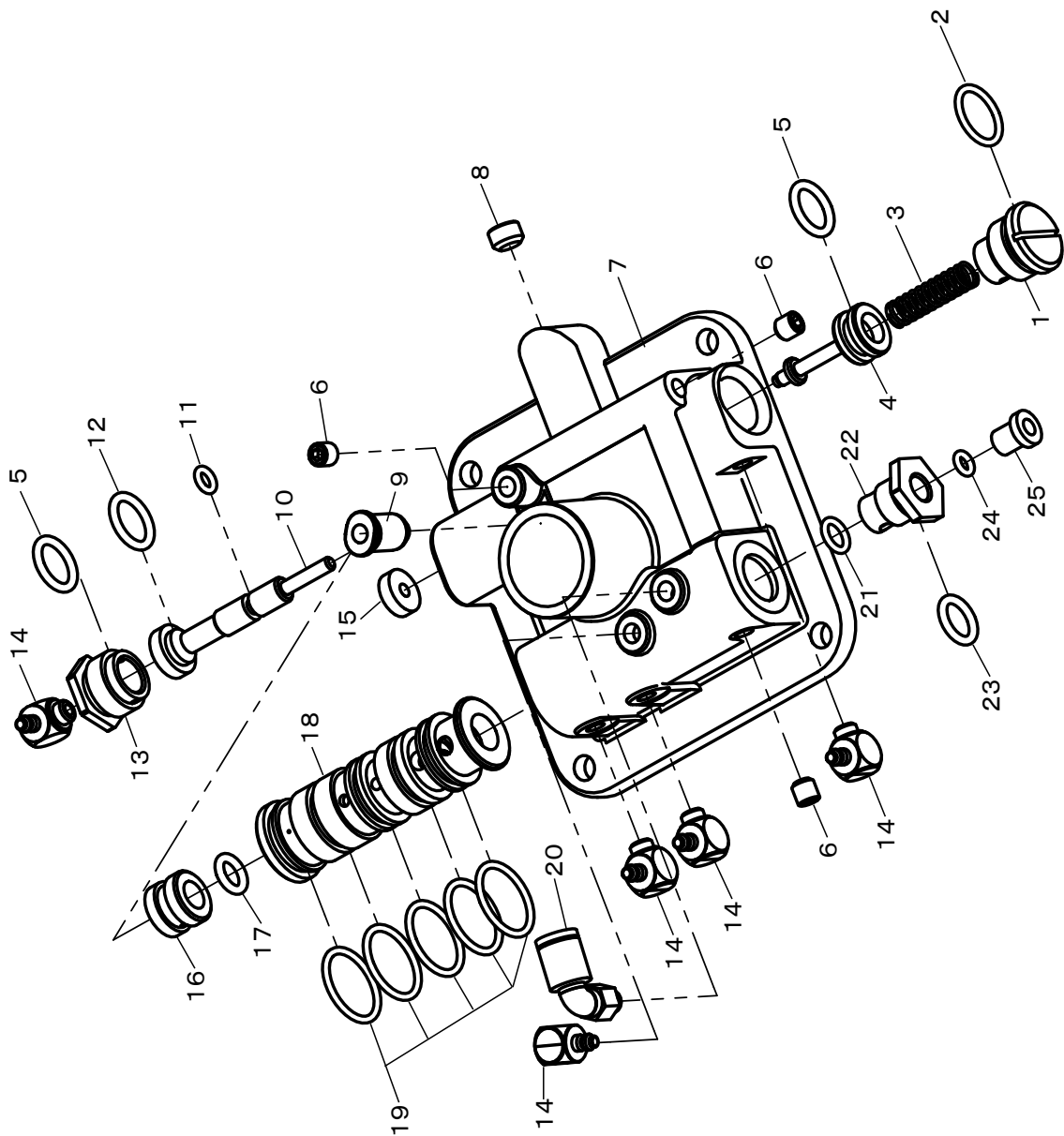

Index No.	Part name	Code No.	Material
1	Spool cap	64895	Aluminum
2	O-ring S-12	23709	Rubber
3	Spool spring	64918	Steel
4	Spool axis	40474	Aluminum
5	O-ring P-9	10219	Rubber
6	Hexagon socket head cap set screw M5×5	64960	Steel
7	Cylinder cap	64894	Aluminum
8	Screw M7 × 1	63245	Plastic
9	One touch straight joint	43738	①
10	Reverse valve	64914	Aluminum
11	O-ring S-4	29664	Rubber
12	O-ring P-10B	64905	Rubber
13	Reverse valve cap A	64915	Aluminum
14	Barb elbow for soft tube	63226	Brass
15	Spool seal	40475	Plastic
16	Collar	64913	Aluminum
17	O-ring P-6	10150	Rubber
18	Reverse valve sleeve	64912	Aluminum
19	O-ring S-15	63988	Rubber
20	One touch joint elbow	64959	①
21	O-ring S-6	10220	Rubber
22	Reverse valve cap B	64896	Aluminum
23	O-ring P-7	10149	Rubber
24	O-ring S-3	64961	Rubber
25	Cap	64897	Aluminum

Unit parts materials

① Brass、Rubber、Stainless、Plastic

● STORAGE

- Store in a place which is well-ventilated and free from excessive dust and humidity and where there is no danger that tool will fall.
- If the tool has not been used for a long period of time, inspect the parts as shown in "Maintenance" on pages 14 to 16 prior to storing the tool.
- To increase the working life of the tool, it is recommended that you maintain and service the tool as recommended in this manual.

Contact the place of purchase or your nearest "LOBSTER" dealer for any overhauls and repair work required.

● ORDERING PARTS

Specify the models, parts names, code numbers., and the quantities of parts as shown below, and place an order with the "LOBSTER" dealer where you purchased the tool.

Model	Part name	Code No.	Qty.
N1A2	Switch	29348	1
N1A2	Frame head	64901	1

※ When parts are modified for improvement, the older parts are kept in stock for a period of five years.

Reference

Rivet nut

- Be sure to use rivet nuts with this tool.
- See our latest product catalogue for LOBSTER rivet nut specifications.

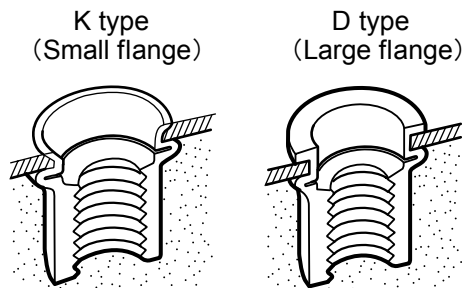

Applicable thread sizes from M3 to M12 are available.

For details, contact the "LOBSTER" dealer where you purchased the tool.

● TROUBLESHOOTING

If a problem occurs, check the followings. If the problem persists after checking the items in the table below, contact your nearest "LOBSTER" dealer or direct to us.

In making any enquiries about this product or requests for repair work, first check the troubleshooting items below, and then make a note of the model number, the usage conditions and the trouble symptoms in as much detail as possible. If you can provide this kind of information, it will contribute reducing the amount of time required for delivery or repairs to be completed.

Trouble	Cause	Countermeasure
The screw mandrel does not rotate.	It may not rotate at the timing when air motor is in neutral position.	Manually turn the screw mandrel to the left and right.
The screw mandrel does not reverse even when the reverse button is pressed.		
The screw mandrel rotates normally, but it does not load the rivet nut.	The size of the screw mandrel does not match the size of the rivet nut.	Replace the screw mandrel with one of the correct size.
	The threaded section of the screw mandrel is damaged.	Replace the screw mandrel with a new one.
	There is no lubrication inside the screw mandrel and mandrel case.	Apply molybdenum grease to the collar and threads of the screw mandrel.
The screw mandrel rotates and moves into the rivet nut, but without pulling up the rivet nut the screw mandrel switches to reverse.	Hydraulic oil level is low.	Add hydraulic oil.
	Stroke adjustment is incorrect.	Re-adjust the stroke.
The screw mandrel rotates and pulls up the rivet nut, but the screw mandrel does not switch to reverse.	Hydraulic oil level is low.	Add hydraulic oil.
	Stroke adjustment is incorrect. (Stroke is longer than required pull up length)	Re-adjust the stroke.

HYDRAULIC OIL REQUIREMENTS

Use only clean hydraulic oil, as the viscosity of the oil used will affect tool performance.

"LOBSTER" brand Hydraulic Oil is supplied in a plastic filler bottle with the tool, and can also be obtained from your "LOBSTER" dealer or agent in your town. If this is not possible, a good quality mineral oil with the following properties should also be used.

Viscosity ISO :VG46

Viscosity Index :113

Viscosity at 40°C :46 c.s.t.

Viscosity at 100°C :7.06 c.s.t.

Flash Point :228

RECOMMENDED OILS are:

Shell Tellus No.46

Esso Teresso No.46

Mobil D.T.E. 25 Oil(Medium)

WARRANTY & SERVICE

LOBSTER® WARRANTS THAT GOODS COVERED BY THIS MANUAL WILL CONFORM TO APPLICABLE SPECIFICATIONS AND DRAWINGS AND THAT SUCH GOODS WILL BE MANUFACTURED AND INSPECTED ACCORDING TO GENERALLY ACCEPTED PRACTICES OF COMPANIES MANUFACTURING INDUSTRIAL TOOLS. THERE ARE NO WARRANTIES WHICH EXTEND BEYOND THE FOREGOING.

THE LIABILITY OF LOBSTER® ON PARTS FOUND TO BE DEFECTIVE IS LIMITED TO RE-WORK OR THE REPLACEMENT OF SUCH GOODS AND IN NO CASE TO EXCEED THE INVOICE VALUE OF THE SAID GOODS. UNDER NO CIRCUMSTANCES WILL LOBSTER® BE LIABLE FOR DAMAGES OR COSTS INCURRED BY THE BUYER OR SUBSEQUENT USER IN REPAIRING OR REPLACING DEFECTIVE GOODS.

ROUTINE MAINTENANCE AND REPAIR OF LOBSTER® RIVET TOOLS CAN BE PERFORMED BY AN AVERAGE MECHANIC.

HOWEVER, IF YOU HAVE A LOBSTER® RIVET TOOL THAT IS IN NEED OF MAJOR REPAIR WE RECOMMEND THAT IT BE SENT DIRECTLY TO US POSTAGE PAID FOR SERVICE AT A REASONABLE CHARGES.

MANUFACTURER

LOBTEX CO., LTD.

OSAKA, JAPAN